

GL Exercise Stations and Features

Bench Press/Row Station with adjustments

This allows for different size users and also provides a variety of Exercises including Bench Press, Incline Press, Shoulder Press and Mid Row. Seat and Back Pad are adjustable. Back pad tilts to ensure full support when performing incline and shoulder presses.

Low Pulley Station with foot plate for Low Rows, Abductor and Adductor Leg Kicks, Arm Curls, Upright Rows, etc.

High Pulley Station for Lat Pull Downs, Triceps Push Downs, etc.

Ab Crunch Mid Pulley Station for Core Training.

Leg Extension and Curl Station provides Seated Leg Extension and Standing Leg Curl.

Weight Stack provides up to 150 lbs. of resistance. Optional 50 lbs. available for up to 200 lbs. of resistance. Optional Stack Guards Available. (Shown)

Space saving design allows placement against a wall, or in a Corner.

Leg Press/Calf Raise option

Available (2:1 Ratio)

for complete Leg and Calf development.



Warranty
Residential Use:
 Lifetime Frame and Parts*
Warranty Light
Commercial Use:
 10 Years Frame,
 2 Years Parts*
 *Against Manufacturers
 Defects.

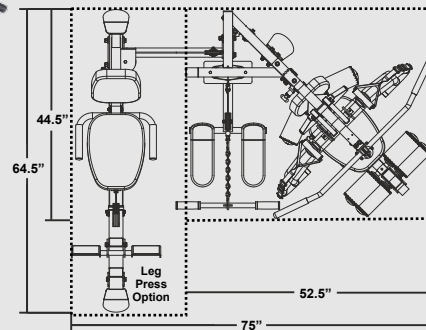

Dimensions

Floor Space: 52.5" X 44.5" X 82.5"
 w/Leg Press Option: 75" x 64.5" x 82.5"

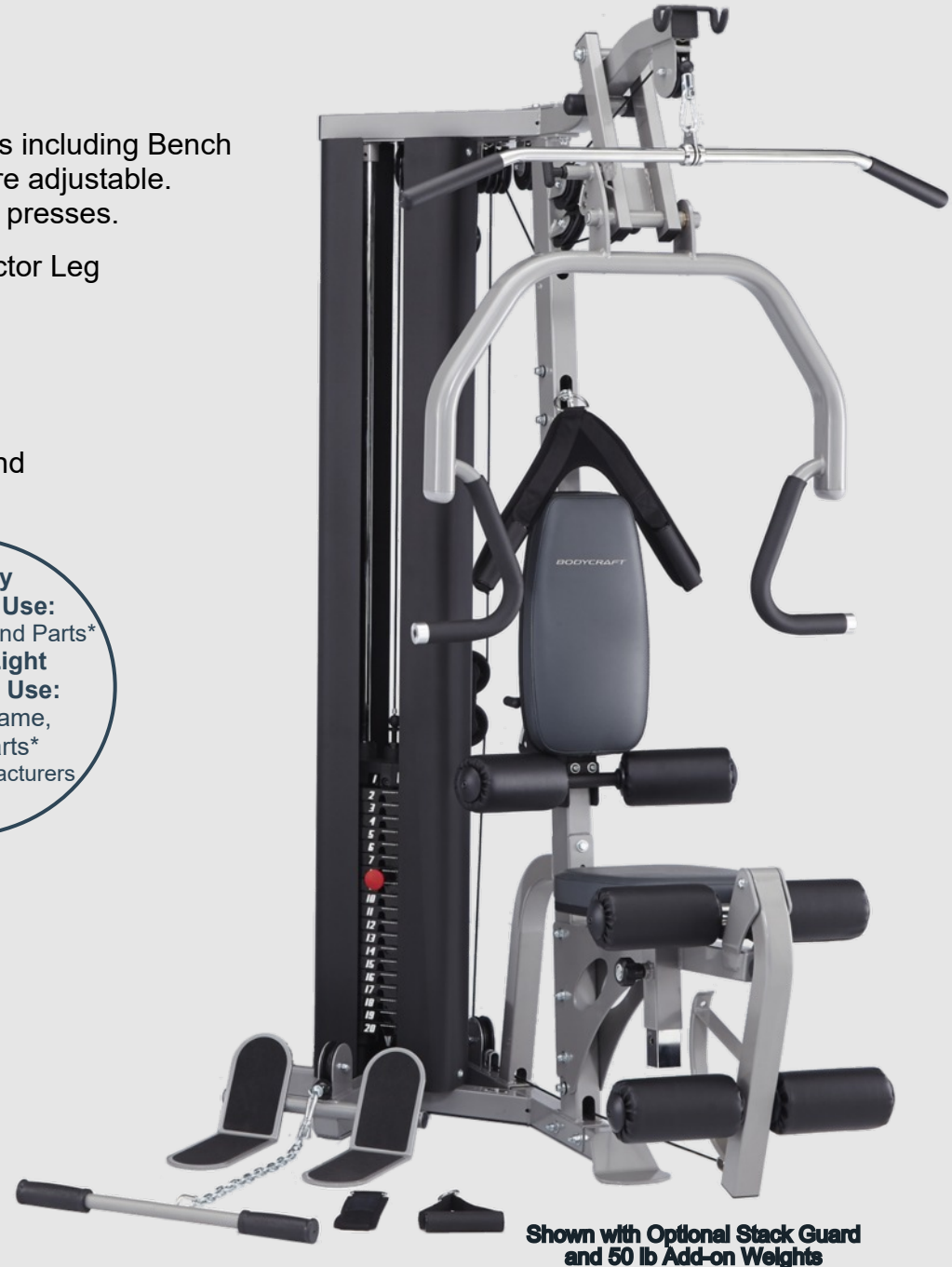

Shown with Optional Stack Guard and 50 lb Add-on Weights

BODYCRAFT reserves the right to make improvements and changes without notice.



www.bodycraft.com



800-990-5556



info@bodycraft.com



7699 Green Meadows Dr.
 Lewis Center. OH 43035.